

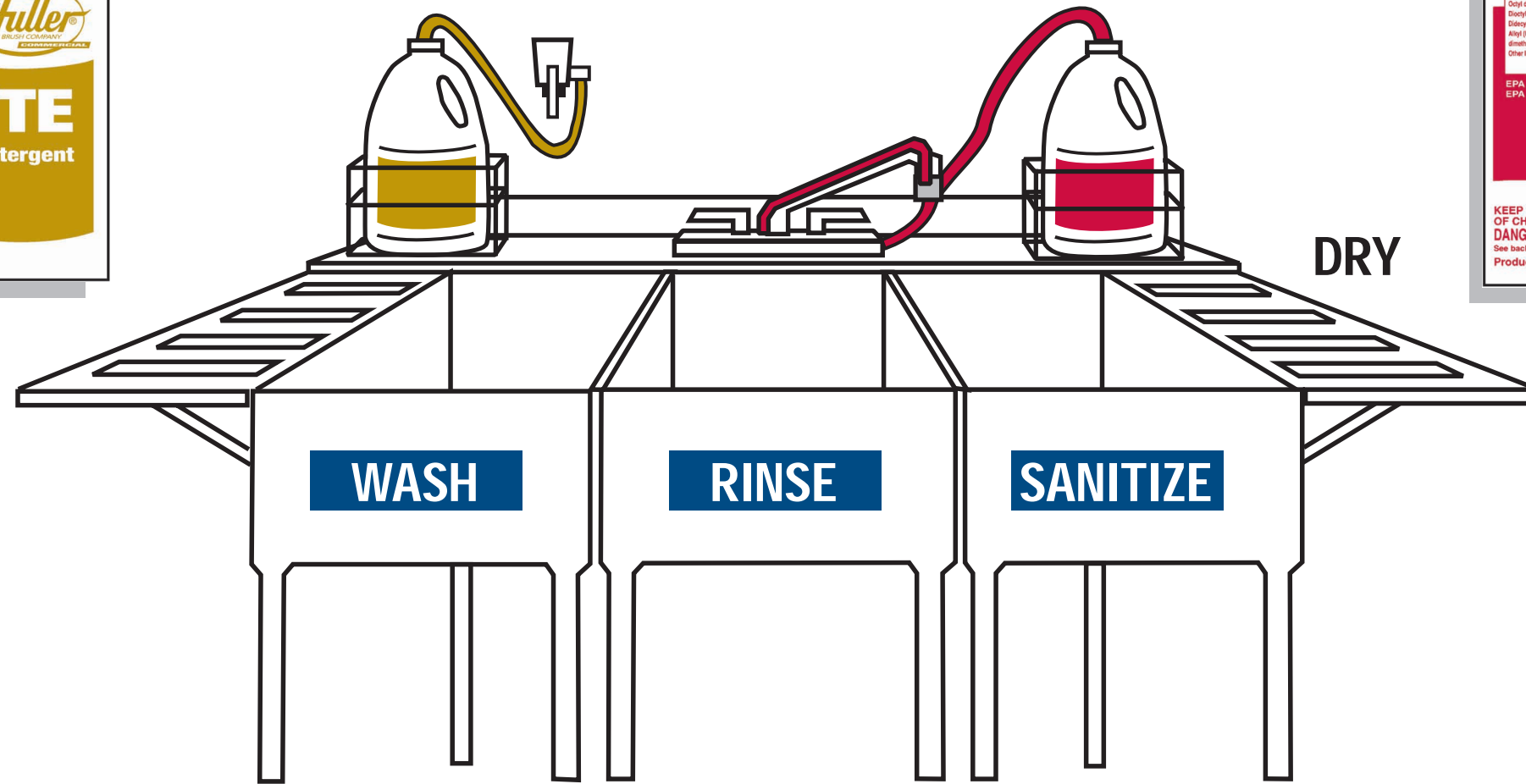

# Triple Sink Procedure

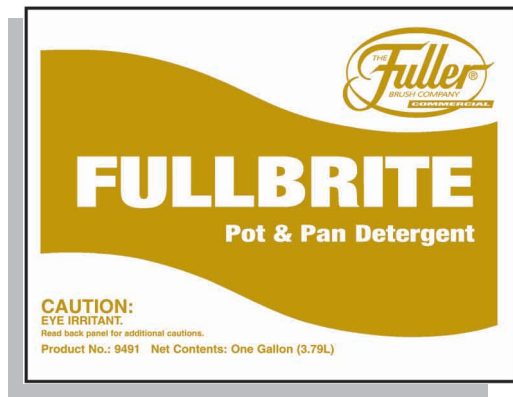

## SINK PREPARATION

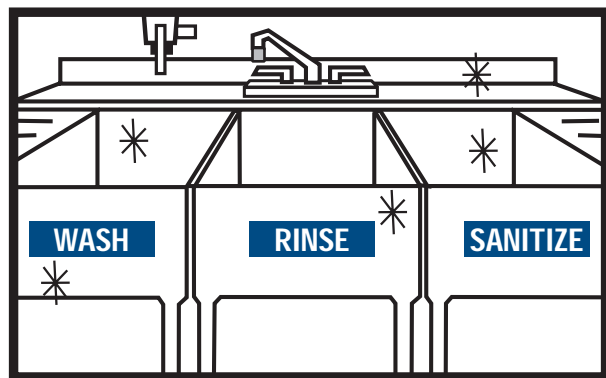

Make sure all sink compartments are thoroughly **CLEANED** and **SANITIZED**.

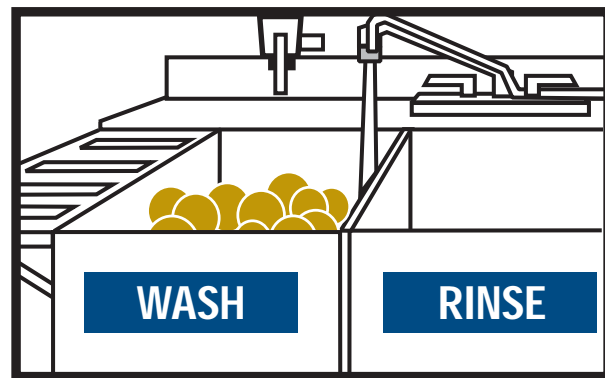

Fill the wash compartment with **FULLBRITE** solution from the detergent proportioner.

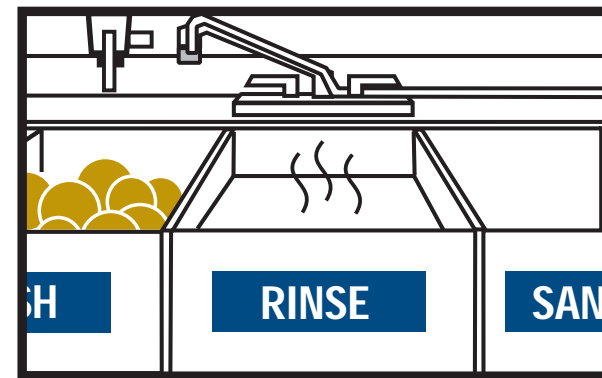

Fill the rinse compartment with **CLEAN, HOT** water.

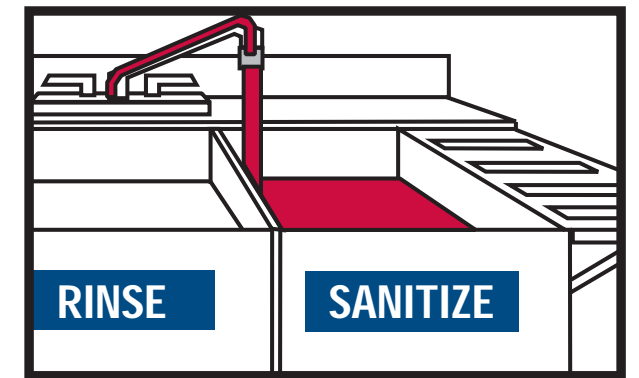

Fill the sanitizer compartment with **FULLSAN 375** solution from the sanitizer proportioner.

## WASHING AND SANITIZING THREE-COMPARTMENT SINK



If necessary, scrape and pre-soak heavily soiled items in a lug filled with **FULLBRITE** solution before washing.



Wash all lightly soiled items first – heavily soiled items last. Refill wash sink when foam dissipates.

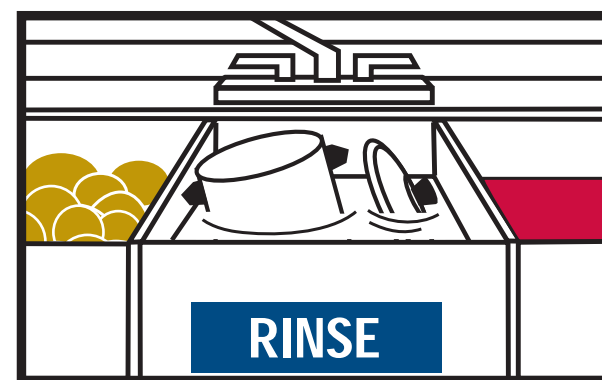

Rinse all items in middle compartment. Refill when rinse water becomes dirty.



Sanitize all items by allowing at least 2 minutes of contact time. Drain and refill with **FULLSAN 375** solution when strength is below 200 PPM.

## SANITIZER TEST

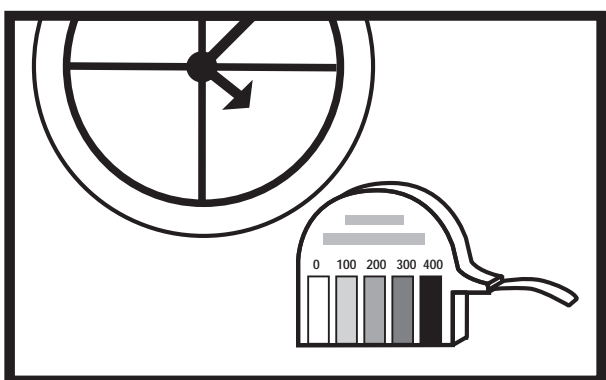

Check **FULLSAN 375** solution frequently, at least 4 times a day.

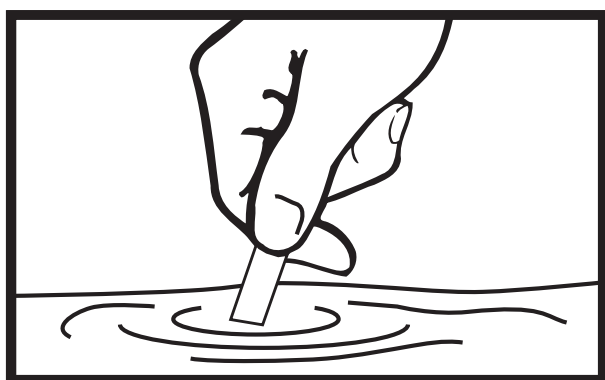

Immerse proper test strip into **FULLSAN 375** solution for 10 seconds.

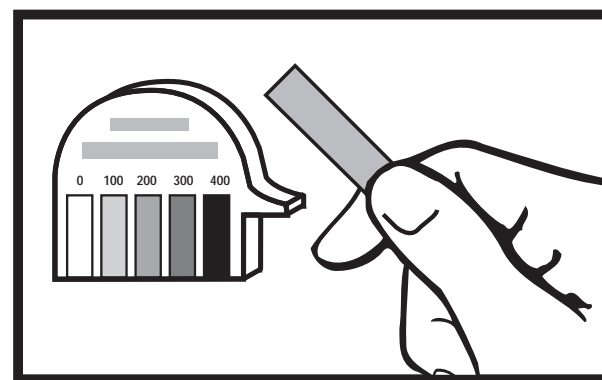

Compare the wet test strip to the color chart located on the test strip case.

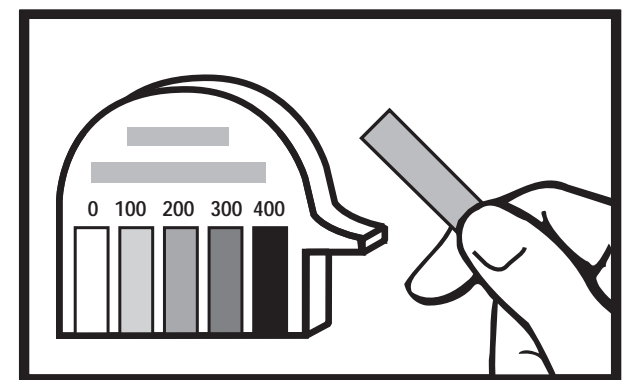

Solution strength should be 200 PPM.



Distributed By:

MSDS Fax Retrieval: **800-551-0101** CHEMTREC Day or Night: **800-424-9300**  
TECH HOTLINE: **800-810-4829**

READ and FOLLOW all directions before using products.